



PF-66 SERIES

22.5° PROFILE REMOVABLE DOME SEPARATOR

FEATURES

- Available in flow rates from 220 to 12,000 GPM.
- Particulate removal efficiencies of 98% at 74 microns and larger expected.
- 150 psi working pressure.
- Fusion bonded polyester coated carbon steel vessel.
- Accumulation chamber clean-out standard.
- True tangential entry.
- Industrial grade manual purge valve.
- 1/4" manual air bleed valve.
- 0-160 psi gauges on inlet/outlet.
- Options: Auto purge, higher pressure ratings, ASME code stamp and stainless steel construction available.



APPLICATION

PUROFLUX's PF-66 series separators are designed specifically to improve the quality of process fluids where space requirements are limited. PF-66 separators provide an excellent method for removing dirt, sand, silt, precipitates and suspended solids from a variety of process fluids. Equipped with a removable dome the interior of the PF-66 separator can easily be accessed for inspection.

TYPICAL APPLICATIONS INCLUDE:

- | | | |
|----------------------|-------------------------|------------------------|
| • Cooling Towers | • Well Water | • Industrial Processes |
| • Food Industries | • Waste Water Discharge | • Automotive Processes |
| • Aquatic Exhibits | • Potable Water | • Chemical Processes |
| • Irrigation Systems | • Fish Hatcheries | • Car Washes |

RELIABILITY

The PF-66 series has a simple and reliable design which offers long lasting trouble free service. The simplicity of the PF-66 separator warrants its use when a solid-liquid separation is required. The PF-66 series separators have no moving parts to wear out or replace, eliminating mechanical malfunction or breakdown.

SERVICE

Technical field service representatives are available to provide guidance for application, installation and repair in both domestic and international markets.

AFFORDABILITY

PUROFLUX's PF-66 series separators can be applied to a variety of applications ranging from single pass/full flow to multiple pass/side stream systems. Optional configurations can be engineered to meet specific requirements.

PF-66/02_10



誥鑫企業有限公司
ARITH COMPANY LTD.

地址：台北市 105 復興北路 427 巷 30 號
電話：(02)2717-5038 (代表號)
傳真：(02)2717-5039
郵件：taipei@arith.com.tw
網址：www.arith.com.tw



PUROFLUX

CORPORATION
FILTRATION AND CONTROL SYSTEMS

PF-66 SERIES - 22.5° Profile Removable Dome Separator

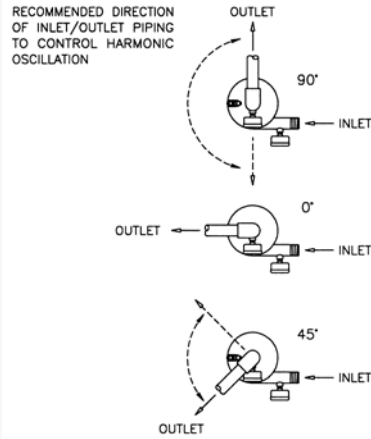
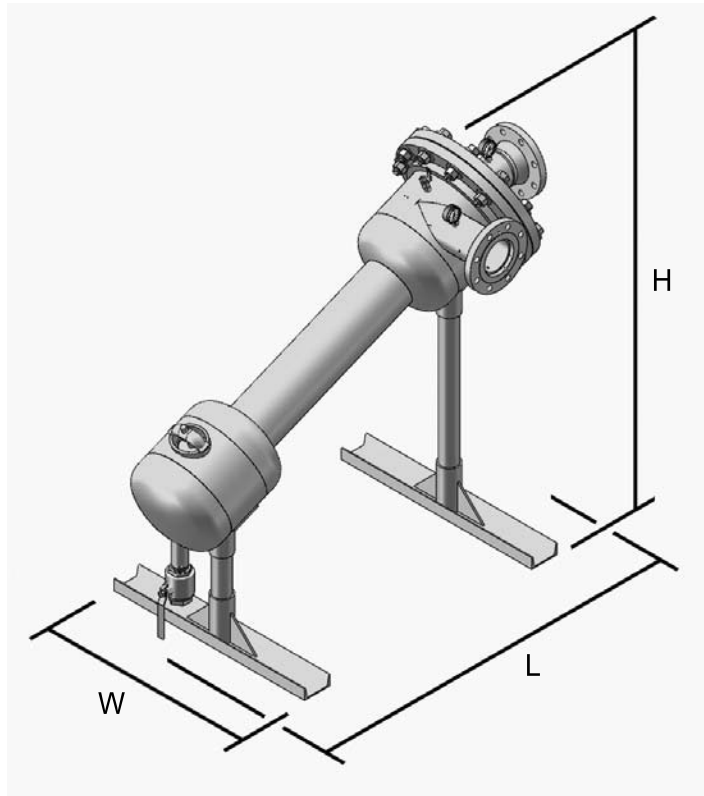

MODEL	FLOW RANGE	CONNECTION	PURGE	VOLUME	DIMENSIONS			WEIGHT, LBS	
Number	GPM	Size	Size	Gallons	L	H	W	Shipping	Oper.
PF-66-040	220 - 440	4" flng	1 1/2" fpt	13	55"	50"	30"	360	468
PF-66-050	375 - 750	5" flng	1 1/2" fpt	21	63"	54"	30"	485	660
PF-66-060	620 - 1245	6" flng	1 1/2" fpt	34	74"	60"	30"	670	952
PF-66-080	1170 - 2355	8" flng	1 1/2" fpt	56	87"	70"	40"	922	1387
PF-66-100	1965 - 3930	10" flng	2" fpt	107	104"	83"	40"	1480	2368

Consult factory for larger sizes not shown.

Flow Rate vs. Pressure Loss

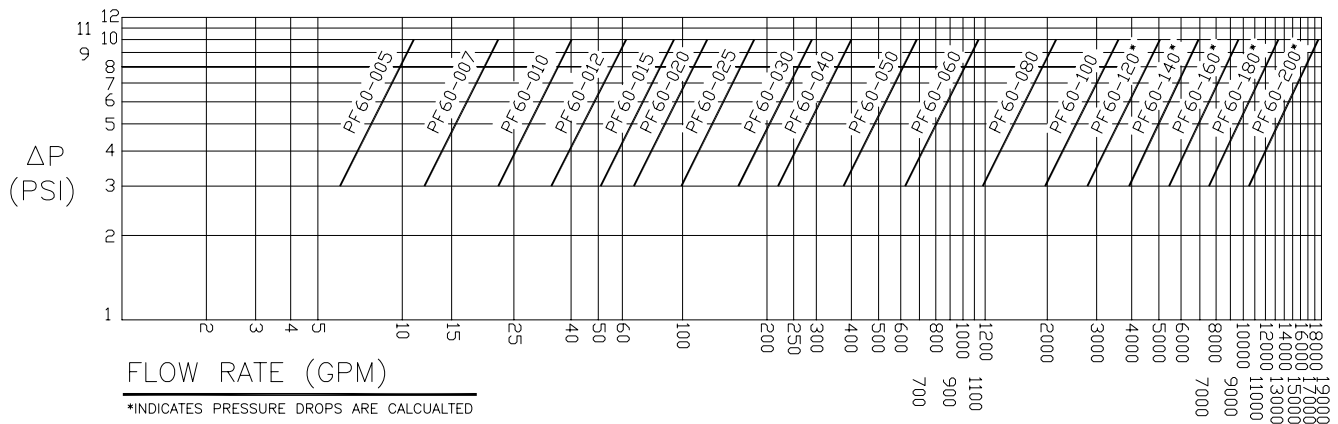

誥鑫企業有限公司
ARITH COMPANY LTD.

地址：台北市 105 復興北路 427 巷 30 號
 電話：(02)2717-5038 (代表號)
 傳真：(02)2717-5039
 郵件：taipei@arith.com.tw
 網址：www.arith.com.tw



PUROFLUX

CORPORATION
FILTRATION AND CONTROL SYSTEMS