

# PF-62 SERIES

## REMOVABLE DOME SEPARATOR

### FEATURES

- Available in flow rates from 20 to 12,000 GPM.
- Particulate removal efficiencies of 98% at 74 microns and larger expected.
- 150 psi working pressure.
- Fusion bonded polyester coated carbon steel vessel.
- Accumulation chamber clean-out (std. on 4" unit and larger).
- True tangential entry.
- Industrial grade manual purge valve.
- 1/4" manual air bleed valve.
- 0-160 psi gauges on inlet/outlet.
- Options: Auto purge, higher pressure ratings, ASME code stamp and stainless steel construction available.



### APPLICATION

PUROFLUX's PF-62 series separators are designed specifically to improve the quality of process fluids. PF-62 separators provide an excellent method for removing dirt, sand, silt, precipitates and suspended solids from a variety of process fluids. Equipped with a removable dome, the interior of the PF-62 separator can easily be accessed for inspection.

### TYPICAL APPLICATIONS INCLUDE:

- Cooling Towers
- Food Industries
- Aquatic Exhibits
- Irrigation Systems
- Well Water
- Waste Water Discharge
- Potable Water
- Fish Hatcheries
- Industrial Processes
- Automotive Processes
- Chemical Processes
- Car Washes

### RELIABILITY

The PF-62 series has a simple and reliable design which offers long lasting trouble free service. The simplicity of the PF-62 separator warrants its use when a solid-liquid separation is required. The PF-62 series separators have no moving parts to wear out or replace, eliminating mechanical malfunction or breakdown.

### SERVICE

Technical field service representatives are available to provide guidance for application, installation and repair in both domestic and international markets.

### VERSATILITY

PUROFLUX's PF-62 series separators can be applied to a variety of applications ranging from single pass/full flow to multiple pass/side stream systems. Optional configurations can be engineered to meet specific requirements.

PF-62/02\_10



誥鑫企業有限公司  
ARITH COMPANY LTD.

地址：台北市 105 復興北路 427 巷 30 號  
電話：(02)2717-5038 (代表號)  
傳真：(02)2717-5039  
郵件：taipei@arith.com.tw  
網址：www.arith.com.tw



CORPORATION  
FILTRATION AND CONTROL SYSTEMS

# PF-62 SERIES - Removable Dome Separator

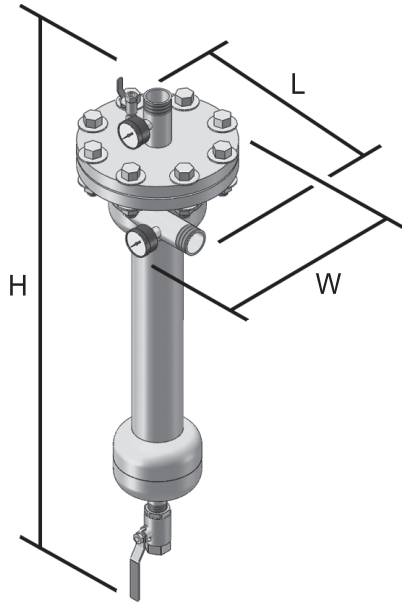

RECOMMENDED DIRECTION OF INLET/OUTLET PIPING TO CONTROL HARMONIC OSCILLATION

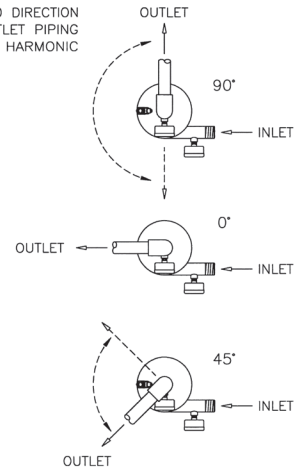

| MODEL Number | FLOW RANGE GPM | CONNECTION Size | PURGE Size | VOLUME Gallons | DIMENSIONS |      |     | WEIGHT, LBS |       |
|--------------|----------------|-----------------|------------|----------------|------------|------|-----|-------------|-------|
|              |                |                 |            |                | L          | H    | W   | Shipping    | Oper. |
| PF-62-010    | 20 - 45        | 1" mpt          | 3/4" fpt   | 2              | 11"        | 36"  | 11" | 67          | 80    |
| PF-62-012    | 35 - 70        | 1 1/4" mpt      | 1" fpt     | 2              | 11"        | 39"  | 11" | 69          | 82    |
| PF-62-015    | 50 - 100       | 1 1/2" mpt      | 1" fpt     | 2              | 11"        | 39"  | 11" | 70          | 83    |
| PF-62-020    | 65 - 135       | 2" mpt          | 1" fpt     | 7              | 16"        | 46"  | 16" | 180         | 234   |
| PF-62-025    | 100 - 200      | 2 1/2" mpt      | 1" fpt     | 7              | 16"        | 46"  | 16" | 182         | 236   |
| PF-62-030    | 160 - 315      | 3" flng         | 1" fpt     | 7              | 18"        | 49"  | 16" | 202         | 260   |
| PF-62-040    | 220 - 440      | 4" flng         | 1 1/2" fpt | 13             | 25"        | 60"  | 19" | 335         | 443   |
| PF-62-050    | 375 - 750      | 5" flng         | 1 1/2" fpt | 21             | 26"        | 71"  | 21" | 463         | 637   |
| PF-62-060    | 620 - 1245     | 6" flng         | 1 1/2" fpt | 34             | 29"        | 82"  | 24" | 648         | 932   |
| PF-62-080    | 1170 - 2355    | 8" flng         | 1 1/2" fpt | 56             | 31"        | 96"  | 25" | 865         | 1330  |
| PF-62-100    | 1965 - 3930    | 10" flng        | 2"- fpt    | 107            | 38"        | 118" | 28" | 1415        | 2306  |

Consult factory for larger sizes not shown.

## Flow Rate vs. Pressure Loss

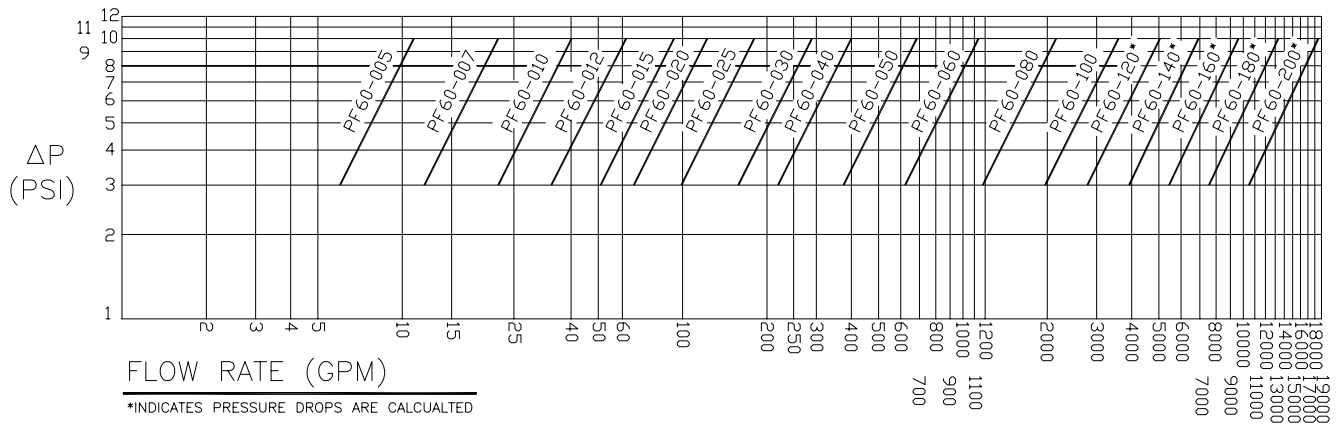

**誥鑫企業有限公司**  
**ARITH COMPANY LTD.**

地址：台北市 105 復興北路 427 巷 30 號  
電話：(02)2717-5038 (代表號)  
傳真：(02)2717-5039  
郵件：taipei@arith.com.tw  
網址：www.arith.com.tw



**PUROFLUX**

**CORPORATION**  
**FILTRATION AND CONTROL SYSTEMS**