

MICROPROCESSOR-BASED REFERENCE ADJUSTER MODEL RA-70

DESCRIPTION

Basler's Microprocessor-based Reference Adjuster, RA-70, is a low burden, variable resistance controller, providing superior performance and reliability over conventional motor operated potentiometers. Applications include voltage regulators, solid state manual voltage control modules, governors, or other devices requiring a low burden, variable resistance for control. The RA-70 has a microprocessor which allows reprogramming at the job site to optimize control of the system.

DEVICE FEATURES

- Microprocessor based design
- Programmable traverse time
- 3 wire Raise/Lower contact control or signal control by 4-20 mA or 0-10 Vdc
- Redundant power supply input: 125 Vdc and 120 Vac
- Two Pre-position set points
- Position indication of set point
- Annunciation: local by LEDs, remote by contacts
- Pushbutton switches for easy calibration and custom field programming
- No potentiometers for adjustment
- Nullmeter output signal for "bumpless" transfer from automatic to manual control
- Autotracking of the automatic voltage regulator by the manual voltage control
- Electrically isolated output
- NRTL/C approved by CSA to U.S. standards (UL508) and to Canadian standards (C22.2 No. 14) for industrial equipment; UL recognized, File #E75380; CSA approved, File #LR23131

APPLICATION

The Microprocessor-based Reference Adjuster, RA-70, provides a means to control any device requiring a low burden, variable resistance such as voltage regulators, excitation systems and speed controllers. This control can be either local or remote. The RA-70 is so flexible that it can replace existing motor operated potentiometers. The resistors are automatically configured to provide a resolution equivalent to a 3-turn potentiometer. The set point can be controlled by a raise/lower contact, a 4-20 mA or 0-10 Vdc signal. A 0-1 mA signal is provided to indicate the position of the set point.

The RA-70 is compatible with all Basler products and systems requiring a variable resistance output. It will also replace competitive motor operated potentiometers, providing faster response, greater control and improved reliability.

APPLICATION

this page

SPECIFICATIONS

page 2

DESIGN FEATURES

pages 2 and 3

ORDERING

pages 4 and 5

ACCESSORIES and APPLICATION DRAWINGS

pages 6 and 7

DIMENSIONS

page 8



BOX 269 HIGHLAND, ILLINOIS 62249, U.S.A. PHONE 618-654-2341 FAX 618-654-2351

SRS-5
9-03

SPECIFICATIONS

- Input Voltage 24 Vdc, 125 Vdc, 120 Vac
- VA Rating 10 VA
- Frequency 50/60 Hz
- Temperature Range -40° to +70°C
- Output Contacts Rating 0.5 Amperes 125 Vdc (Non-Inductive)
- Position Meter Output 0-1 mA, 4,500 Ohm maximum burden
- Traverse Time 5, 10, 20, 40, 60, 80, 100, 120 seconds
- Autotracking Response Delay (for Manual Voltage Control units only) 0, 1, 2, 3, 4, 5, 6, 7 seconds
- Nullmeter Output -1 mA to 0 to +.1 mA, 5,000 ohms maximum burden
- Hipot 1,500 VAC, all terminals connected to ground
- Weight 7 lbs.
- Power Dissipation 10 watts
- Resolution See Table at right
- Output rating 1/4 watt

ELEMENT SIZE	OHM STEP
1,250 OHMS	0.55 OHMS
2,500 OHMS	0.60 OHMS
5,000 OHMS	1.25 OHMS
10,000 OHMS	2.50 OHMS

Two basic versions are readily available; 1) A 2-wire rheostat type (voltage regulators), 2) A 3-wire potentiometer type (Basler manual voltage control modules and SCP 250 VAR/PF controller).

DESIGN FEATURES

1) Power Supply

Standard

The standard power supply is designed for dual power input to ensure continued control during power supply interruption. When 100% AC supply voltage is available, there is no load on the dc power source. If a dual power source is not available, the unit will operate with just one power supply, 120 Vac or 120 Vdc.

An optional 24 Vdc power supply can be specified for the RA-70. This option is only available as a single power source.

2) Raise/Lower Control

Standard - Program Selected

Multiple point three wire control of the raise/lower signal is readily available. A momentary contact closure during the first two seconds causes extremely slow change in the output referenced signal. After two seconds, the unit assumes the normal traverse time programmed into the reference adjuster.

The RA-70 can also be controlled via a Programmable Logic Controller having either mA or voltage signal output. The two modes of operation are described as follows:

A. Linear Control Features (4-20 mA or 0-10 Vdc)

1. Gives a proportional variation in output in 256 steps.
2. Locks out other controls such as Raise/Lower and Pre-Position.
3. Uses programmed traverse rate.
4. Position signal shows location of set point between programmed upper and lower limits (0-1mA output).

B. Step Function Control (4-20 mA or 0-10 Vdc)

Example:

1. 4-5 mA signal represents lower-fast.
 5-8 mA signal represents lower-slow.
 8-14 mA signal represents stop.
 14-17 mA signal represents raise-slow.
 17-20 mA signal represents raise-fast.
2. Position signal shows relative location of set point (0-1 mA output).

DESIGN FEATURES, continued

3) Position Indication

Standard

A Position signal is provided to indicate the percent of travel for the setpoint. The feature is used with any 1 mA panel or switchboard meter. See Accessories for the position meter part numbers.

4) Pre-Position Setpoint Enable #1 and #2

Standard

The unit is designed with two pre-position setpoints, factory set to mid-range. Each pre-position setpoint can be programmed to a user-selected position for precise system control. Each pre-position setpoint can be programmed for two modes of operation.

- A. Pre-Position Maintain: The unit is programmed to seek the pre-position setpoint. Once reached, it will maintain the signal and block all external raise/lower signals until the pre-position command signal is removed.
- B. Pre-Position Release: The unit can be programmed to seek the pre-position setpoint. Once the level has been reached, raise/lower control is returned to the operator.

5) Pushbutton Switches

Standard

A pushbutton control pad is provided to allow programming and control of the RA-70. These switches include raise/lower, pre-position #1 and #2, mode select and programming enable.

6) Output Annunciation

Standard

Annunciation of the raise/lower limits and pre-position #1 and #2 are provided by LED indication. Contacts are also provided for external annunciation.

7) Programmability

Standard

The RA-70 is shipped programmed with Factory Default settings. The unit can be reprogrammed in the field to change those settings. These include:

- A. Upper/Lower Limits
- B. Pre-Position Setpoints
- C. Traverse Time
- D. Raise/Lower Contact or 4-20 mA, 0-10 Vdc signal control
- E. Tracking Response Time Delay (available for use with RA-70M only)
- F. Traverse mode programming to enable/disable the 2-second delay before entering the traverse rate.

Programming is accomplished by use of the pushbutton switches and LEDs on the RA-70.

8) Null Indication

Standard

Null indication is standard on the RA-70M only. A null signal output of -0.1 mA to 0 to $+0.1$ mA is provided for zero reading information to allow safe transfer from the automatic voltage regulator to manual control.

9) Autotracking

Optional

The RA-70M, used with Basler's Manual Voltage Control units, can be purchased with a circuit that causes the manual voltage control to follow the output signal from the automatic voltage regulator. This enables a bumpless transfer between the voltage regulator to manual control without operator intervention. This feature is only available with Raise/Lower contact control.

10) Dual Output Signals

Optional

In applications having dual voltage regulators with rheostat-type output, the Microprocessor-based Reference Adjuster can be selected for dual reference signal outputs. The dual reference signal will allow two setpoints to be varied simultaneously, one for each voltage regulator.

MICRO-BASED REFERENCE ADJUSTER MODEL CODE

Micro-Based Reference Adjuster Model RA-70 for Interface with 2-wire Automatic Voltage Regulator Set point

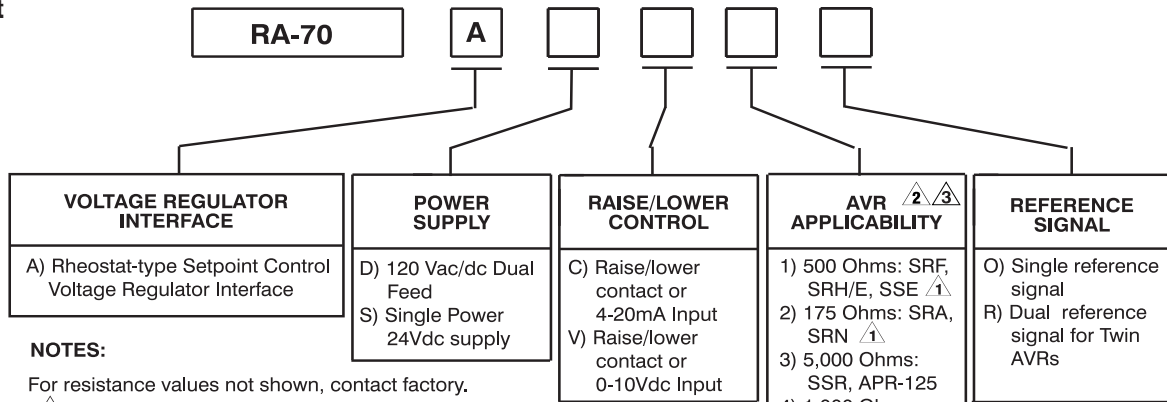

NOTES:

For resistance values not shown, contact factory.

¹ 2,500 Ohm element is used for these units.

² When initiating a raise, operating resistance decreases.

³ When it is desired for the AVC63-12, AVC125-10 voltage regulators, or other devices requiring a raise command to increase resistance, an RA70M or RA70P should be selected. RA70M or RA70P output resistance terminals 3 and 4 should be utilized in two-wire applications to achieve the opposite effect of Note 2.

Micro-Based Reference Adjuster Model RA-70 for Interface with 3-wire Manual Voltage Control Set point

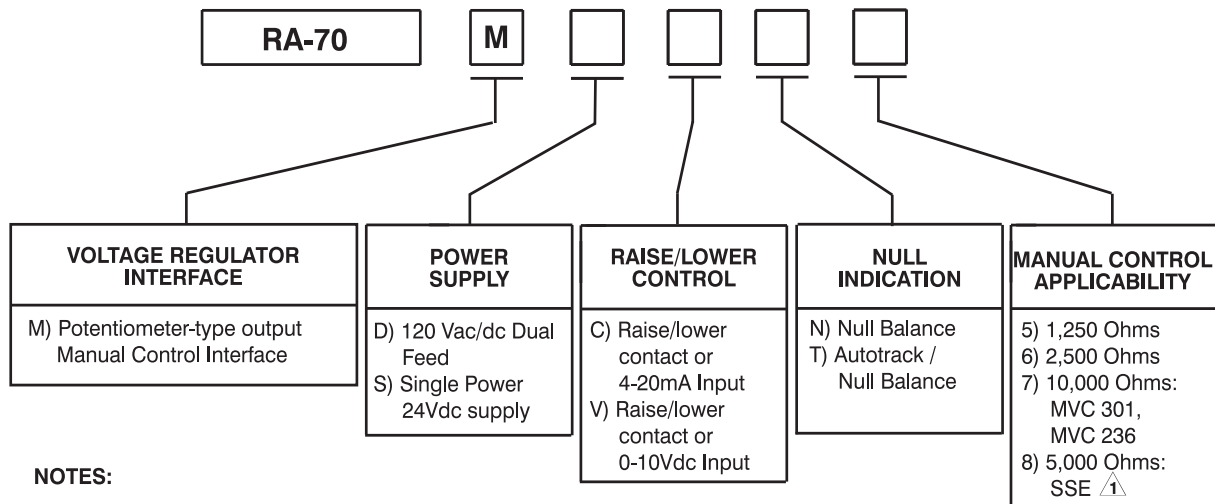

NOTES:

For resistance values not shown, contact factory.

¹ When Manual Control Applicability is "8", then Raise/lower contact or 0-10Vdc Input "V" must be selected

Micro-Based Reference Adjuster Model Number RA-70 for 3-wire Potentiometer-type Interface

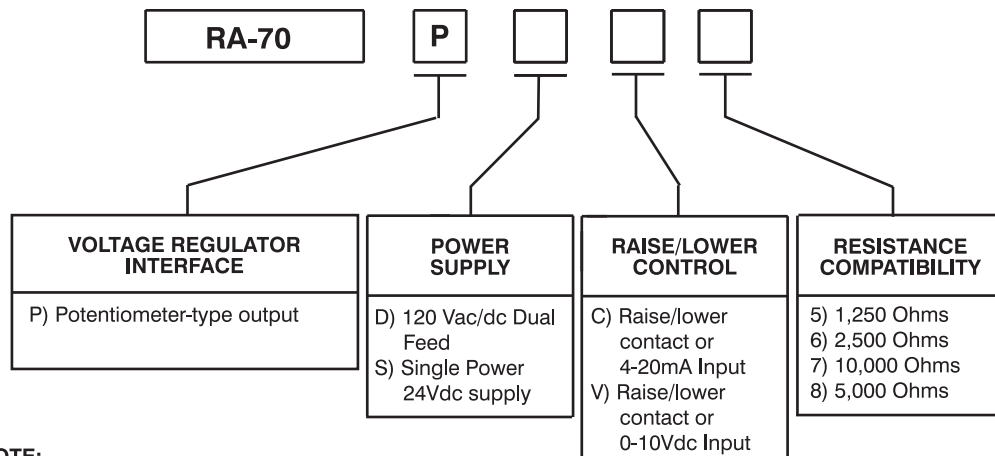

NOTE:

Match the potentiometer resistance in your present circuit with one of the resistance values above. For resistance values not shown, contact factory.

ORDERING

HOW TO ORDER:

Designate the model number, followed by the complete style number.

Style No. RA-70 □ □ □ □ □

Complete the style number by selecting one feature from each column of the Style Number Identification Chart and enter its designation. For output resistances not shown, consult factory.

Three basic models are available: one model for 2-wire rheostat output for use with the Basler voltage regulator, one model with 3-wire potentiometer output used with Basler solid state manual voltage control, and one model with 3-wire potentiometer output.

The model selected is determined by the device it is intended to control.

MODEL NUMBER

RA-70 Micro-Based Reference Adjuster

STYLE NUMBER

The style number appears on the front panel. This style number is an alphanumeric combination of characters identifying features included in a particular unit.

SAMPLE STYLE NUMBER RA-70M DCT7

- (M) Manual Voltage Control Interface
- (D) Dual Feed Power Supply 120 Vac/dc
- (C) Contact Raise/Lower or 4-20 mA Input
- (T) Autotrack/Null Balance Indication
- (7) Manual Control Interface
10,000 ohms: Basler models MVC 301, MVC 236

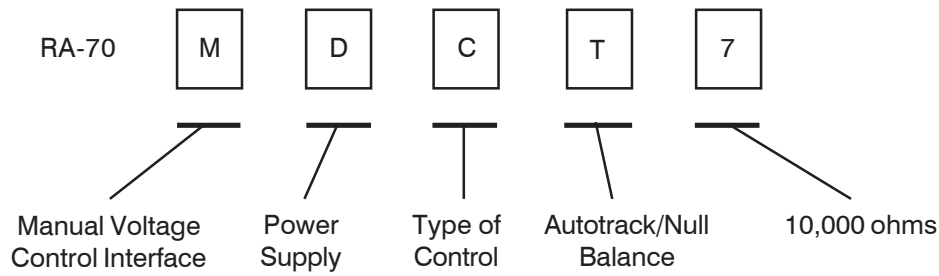

SAMPLE STYLE NUMBER ILLUSTRATED

ACCESSORIES

The following standard accessories are available for the RA-70 Micro-Based Reference Adjuster.

- Position Meter
 - 0-1 mA Switchboard 270° Dial P/N 27824
 - 0-1 mA Edgewise Horizontal Panel Type P/N 27825
- Nullmeter
 - .1 mA, 0, +.1 mA Switchboard 270° Dial P/N 23332
 - .1 mA, 0, +.1 mA Panel Type P/N 27832
- Isolation Transformer
 - 120 Vac to 120 Vac, 50VA, 50-60 Hz BE 25982001
- Raise-Off-Lower Switch P/N 9174805108

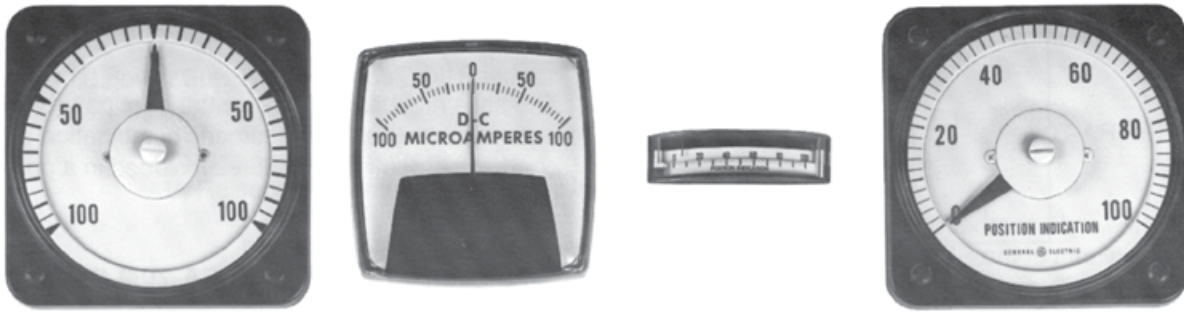

A number of different meter accessories is available for use with the RA-70. Basler offers switchboard or panel type.

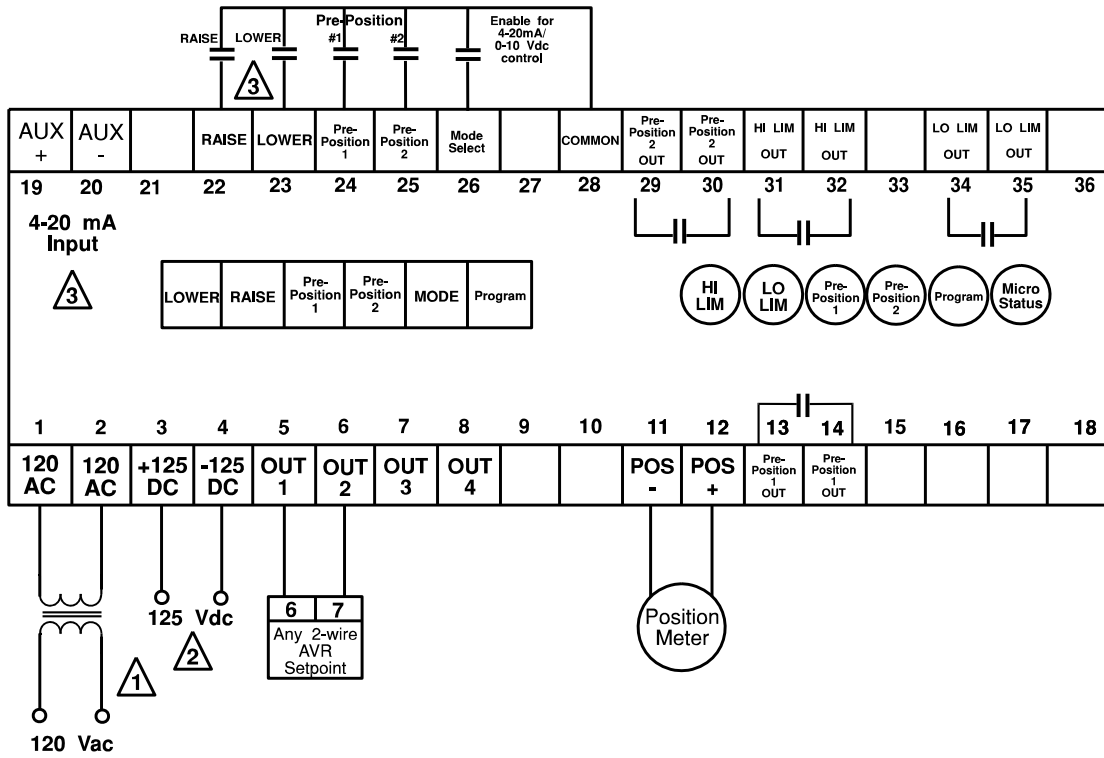

- 1** Electrical isolation is required if AC supply is grounded. See standard accessories.
- 2** Single or dual power supply feed.
- 3** Only one input command can be programmed for operation, 4-20 mA/0-10 Vdc control or contact Raise/Lower.

Figure 1 - Typical 2-Wire Voltage Regulator Application

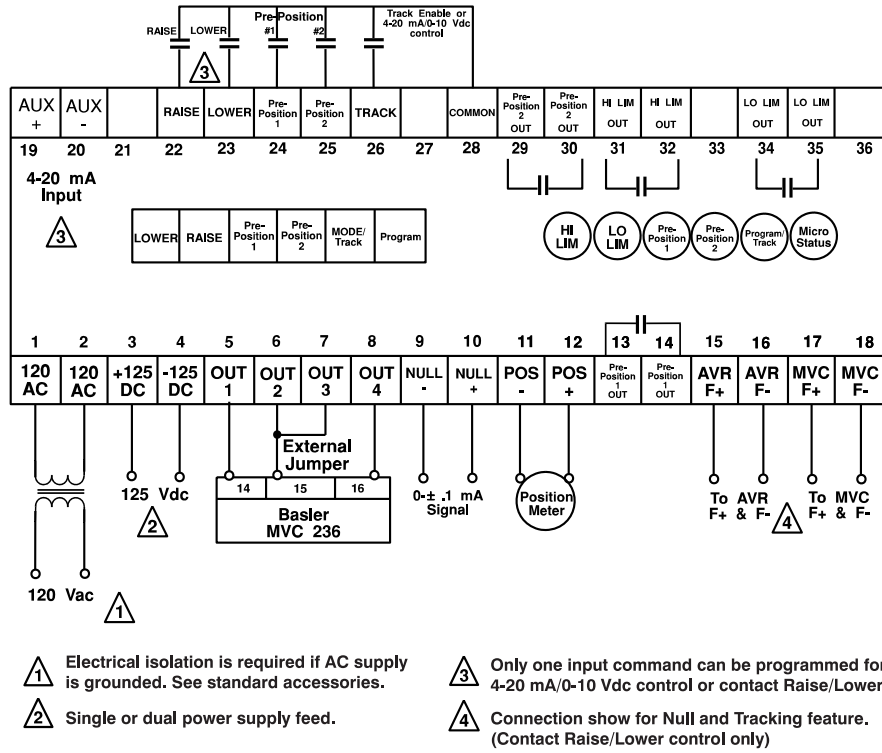

Figure 2 - Typical Manual Voltage control or 3-Wire Potentiometer Application

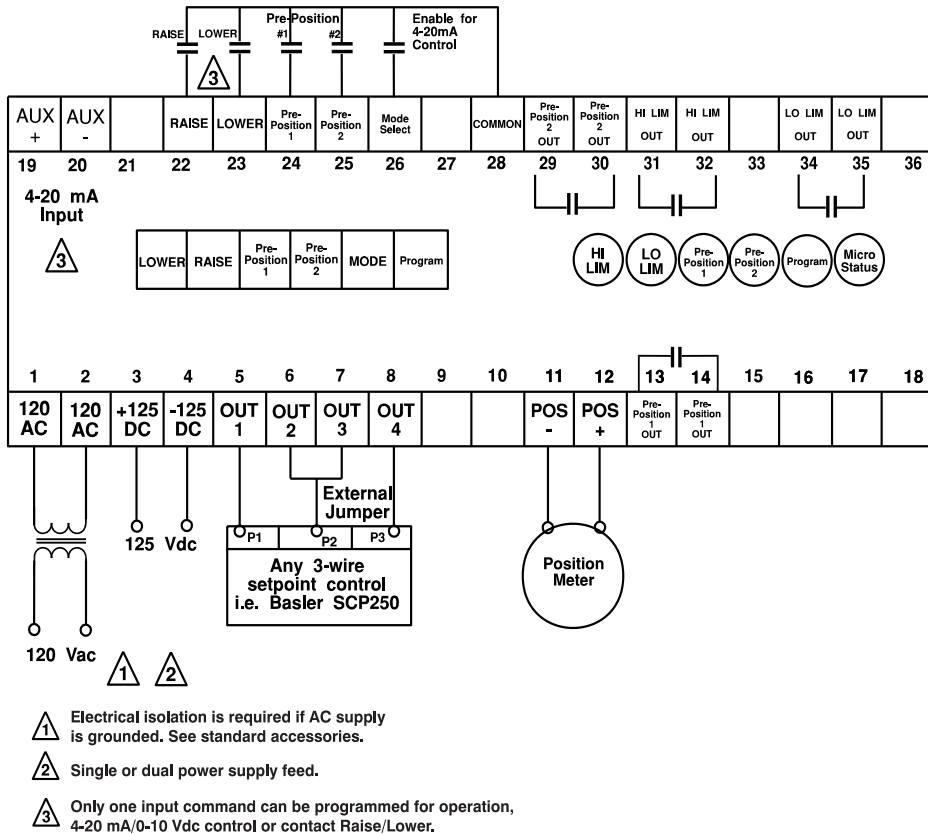

Figure 3 - 3-Wire Potentiometer Application

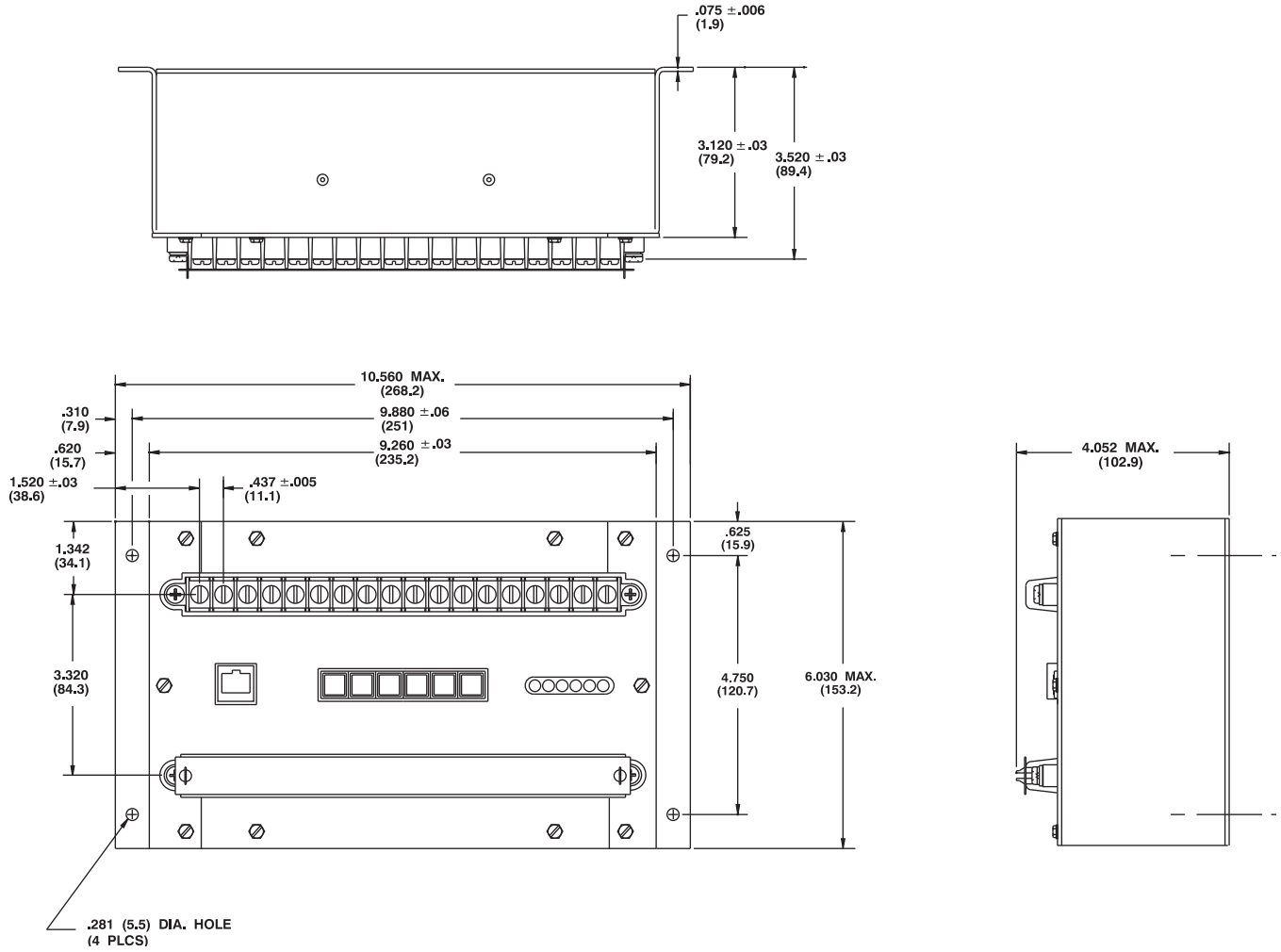

Figure 4 - Outline Drawing of RA-70 Microbased Reference Adjuster



ISO9001-2000
Highland, IL USA Taylor, TX USA
Wasselonne, France Suzhou, China



P.A.E. Les Pins, 67319 Wasselonne Cedex FRANCE
Tel +33 3.88.87.1010 Fax +33 3.88.87.0808
e-mail: beifrance@basler.com

Route 143, Box 269, Highland, Illinois U.S.A. 62249
Tel +1 618.654.2341 Fax +1 618.654.2351
e-mail: info@basler.com

No. 1300 North Zhongshan Road, Wujiang Economic Development Zone
Suzhou, Jiangsu Province - P.R. China 215200
Tel +86(0)512 6346 1730 Fax +86(0)512 6346 1760
e-mail: beichina@basler.com

www.basler.com