

PFRV SERIES

RECOVERY VESSEL

FEATURES

- **Single bag units:** fully constructed of 304 SS with swing type eye-bolt cover.
- **Multi-bag units:** Fusion bonded epoxy lined/polyester coated carbon steel vessel with hinged T-bolt cover.
- **150 psi working pressure** (higher pressure ratings and ASME code available)
- **Stainless steel support basket(s)**
- **1/4" manual air bleed valve**
- **Pressure differential indicator**
- **One year limited warranty**
- **Options:** Auxiliary alarm contact, plumbing package, 25/75/100 micron polyester collection bags.



APPLICATION

PUROFLUX's PFRV series recovery vessels are designed specifically to be used in conjunction with the PF60 series separators for the collection and disposal of separated solids and recovery of purged liquids.

DESIGN

The PFRV recovery vessels are designed to trap separated solids for ease of handling. The PFRV will reduce system fluid loss, clean-up time and large volumes of solid-liquid waste. Purged solids are continuously collected within the recovery vessel without interruption of the process system flow. Standard equipment includes a pressure differential indicator for indicating when a bag change is required. Bag changes are fast and simple with easy access covers.

RELIABILITY

The PFRV series has a simple and reliable design which offers long lasting trouble free service. The simplicity of the PFRV recovery vessel warrants its use when solids collection and liquid recovery is required.

SERVICE

Technical field service representatives are available to provide guidance for application, installation and repair in both domestic and international markets.

AFFORDABILITY

PUROFLUX's PFRV recovery vessel when used in conjunction with the PF60 series separators offers an affordable alternative to other comparable types of filtration, and with its low initial investment, offers a quick return on investment.

PFRV/08



誥鑫企業有限公司
ARITH COMPANY LTD.

地址：台北市 105 復興北路 427 巷 30 號
電話：(02)2717-5038 (代表號)
傳真：(02)2717-5039
郵件：taipei@arith.com.tw
網址：www.arith.com.tw

PFRV SERIES - Recovery Vessel

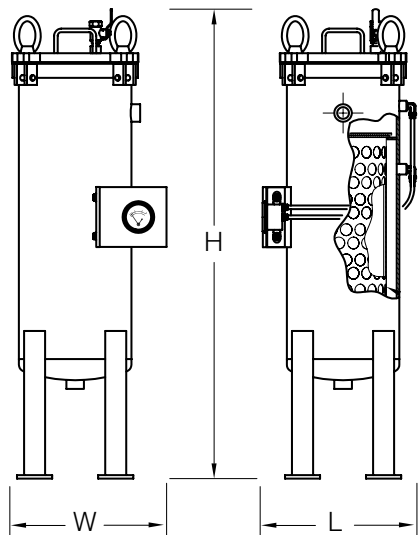

PFRV-1

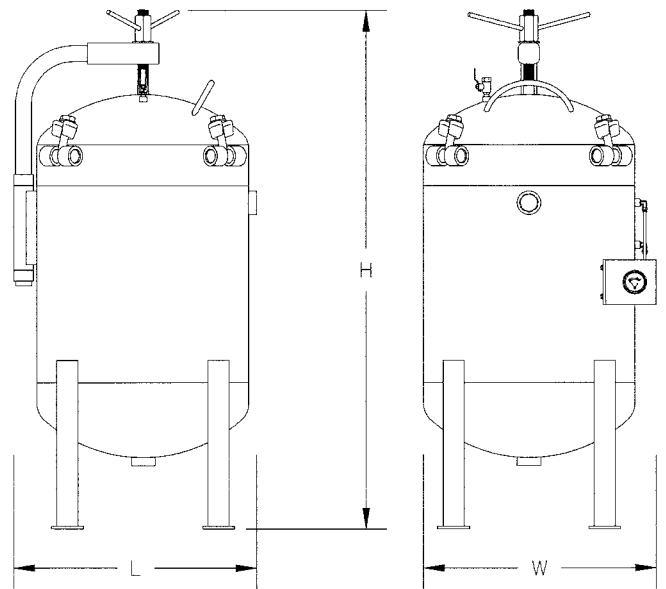

PFRV-3

MODEL Number	SEPARATOR Correlation	PURGE FLOW Rate	CONNECTION Size	VOLUME Gallons	DIMENSIONS			WEIGHT, LBS	
					L	H	W	Shipping	Oper.
PFRV-1S - II	1/2" - 3"	15 gpm	1" fpt	7	12"	33"	13"	50	135
PFRV-1T - II	4" - 8"	20 gpm	1" fpt	9	12"	47"	13"	61	175
PFRV-3S	10" - 14"	30 gpm	1 1/2" fpt	40	23"	48"	22"	325	655
PFRV-3T	16" - 20"	50 gpm	1 1/2" fpt	47	23"	60"	22"	350	745

Consult factory for larger sizes not shown.

PLUMBING PACKAGE:
(OPTIONAL)

- (2) ISOLATION VALVES
- (2) FLOW SIGHT-GLASSES
- (1) FLOW CONTROLLER

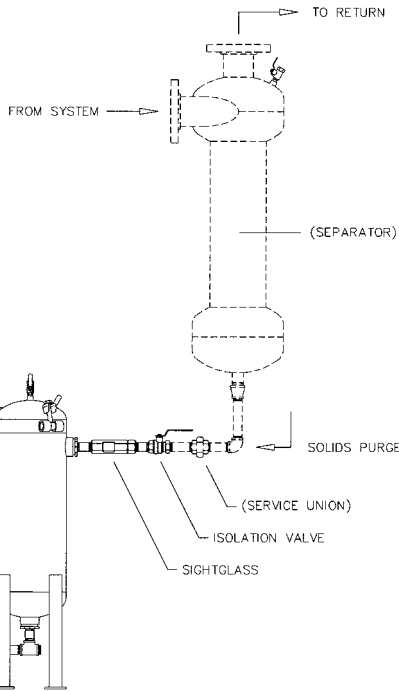

AUXILIARY ALARM CONTACT:
(OPTIONAL)

- (1) PRESSURE DIFFERENTIAL INDICATOR
- (1) AUX. DRY CONTACT
- (1) NEMA 4X CONTROL BOX
- (1) 120 VOLT INDICATING LIGHT

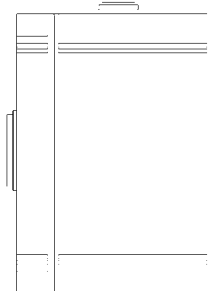
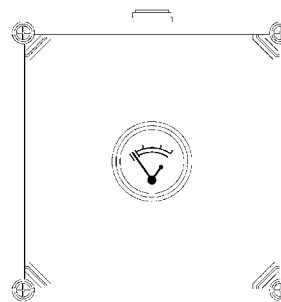
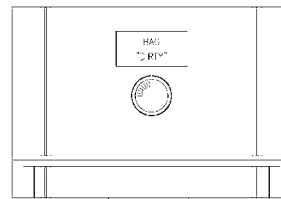

誥鑫企業有限公司
ARITH COMPANY LTD.

地址：台北市 105 復興北路 427 巷 30 號
 電話：(02)2717-5038 (代表號)
 傳真：(02)2717-5039
 郵件：taipei@arith.com.tw
 網址：www.arith.com.tw